

PRODUCT NUMBER
SEE TABLE, SHT 2

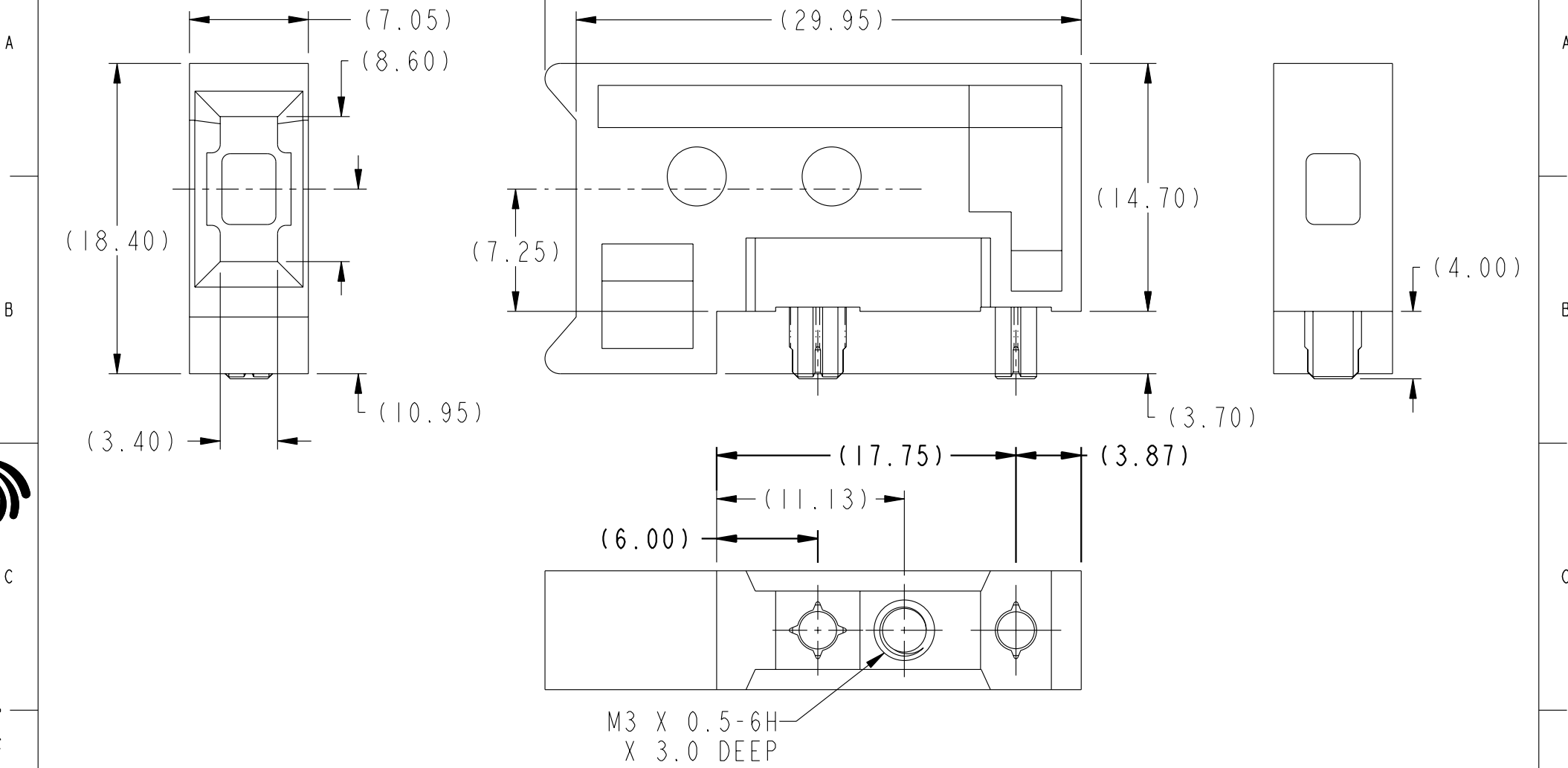

M3 X 0.5-6H
X 3.0 DEEP



Copyright FCI.

rev	ecn no	dr	date
A	V05-0103	AR	01/27/05
B	V05-0262	AR	03/29/05
C	S05-0238	MC	08/25/05
D	S06-0049	CH	05/19/06
-	-	-	-
-	-	-	-
-	-	-	-

www.fciconnect.com		surface 3.200 ASME Y14.5	tolerance std ASME Y14.5	projection MM
TOLERANCES UNLESS OTHERWISE SPECIFIED		0.X ±.3	0.XX ±.10	0.XXX ±.050
Dr	A. RAISTRICK	08/03/04	size	A4
Eng	B. MARSHALL	08/03/04	Scale	3:1
Chr	CH TAN	07/07/06	ECN	S06-0049
Appr	JOEY NG	07/07/06	Product family	AirMax Accessories
FCI		title	7.2mm GUIDE MODULE, RIGHT ANGLE	dwg no
		catalog no	-	CUSTOMER
		Rev.	D	sheet 1 of 2

PRODUCT NUMBER

10037909-101LF

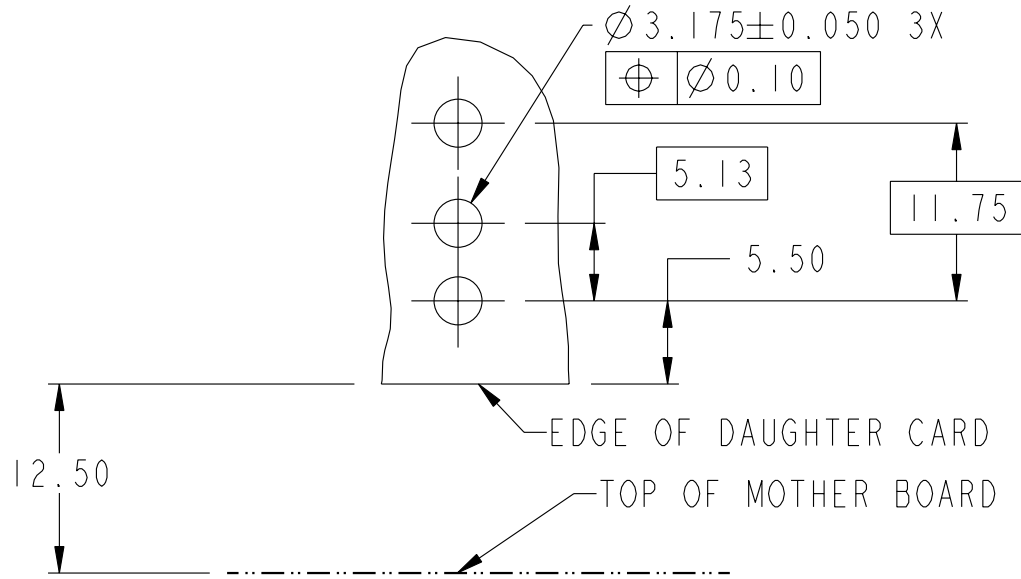

RECOMMENDED PCB LAYOUT NOTE 4
SCALE 2:1

1. MATERIAL: ZINC ALLOY
2. FINISH: ZINC YELLOW CHROMATE
3. APPLICATION SPECIFICATION: GS-20-045
- ④ REFER TO CUSTOMER DRAWING 10035911 FOR INFORMATION REGARDING PBC LAYOUT OF POWER AND GUIDE MODULES RELATIVE TO SIGNAL MODULES
5. THIS PRODUCT MEETS EUROPEAN UNION DIRECTIVES AND OTHER COUNTRY REGULATIONS AS DESCRIBED IN GS-22-008.
6. PACKAGING MEETS GS-14-920 LEAD FREE LABELING SPECIFICATION.



7.2mm GUIDE MODULE, RIGHT ANGLE

dwg no 10037909

Rev. D

catalog no

CUSTOMER

sheet 2 of 2